

# KOMATSU®

**HORSEPOWER**  
Gross: 53 kW 72 HP / 2150 min<sup>-1</sup>  
Net: 50.8 kW 68 HP / 2150 min<sup>-1</sup>

**CAPACITY**  
4000 - 5000 kg

**FH40-1**  
**FH45-1**  
**FH50-1**

**FH**  
**50**



DIESEL FORKLIFT TRUCKS

[www.Komatsu.com](http://www.Komatsu.com)

Printed in Japan 201210 IP.SIN



Photos may include optional equipment.

CEN00514-01

Materials and specifications are subject to change without notice  
**KOMATSU** is a trademark of Komatsu Ltd. Japan

# WALK-AROUND

**HORSEPOWER**  
 Gross: 53 kW 72 HP / 2150 min<sup>-1</sup>  
 Net: 50.8 kW 68 HP / 2150 min<sup>-1</sup>

**CAPACITY**  
 4000 - 5000 kg

## Superior Fuel Economy

- Built upon Komatsu's unique hydraulic and control technologies
- Superior fuel economy in high cycle operations
- Reduced CO<sub>2</sub> emissions
- Electronically-controlled HST
- Variable displacement pump with CLSS
- Variable engine output control function
- Auto engine shutdown function
- Low emission engine

See pages 4 and 5.

## Controllability & Safety

- Smooth directional changes without releasing accelerator pedal
- Controlled rolling back on a ramp
- Less inching pedal use means reduced operator fatigue
- No creeping
- Shock-free shifting
- Travel speed limiter
- Neutral start function

See page 6.



FH50-1

## Durability & Reliability

- High-quality and reliable Komatsu components
- Improved engine starting performance
- Heavy-duty sealed wet disc brakes
- Enhanced brake reliability

See page 7.

## KOMTRAX

- Komatsu machine tracking system

See page 8.



FH40-1



FH45-1



# SUPERIOR FUEL ECONOMY

## New forklift trucks built upon Komatsu's unique hydraulic and control technologies

The FH Series was designed to utilize highly reliable, field-proven Komatsu's drive and control components that have been used for many years in Komatsu construction equipment. The travel system is "Electronically-controlled HST", Komatsu's unique hydraulic drive system that has been employed for Komatsu wheel loaders and bulldozers. The lift hydraulic system uses "Variable displacement pump with CLSS", a highly efficient hydraulic system employed in Komatsu hydraulic excavators. The FH Series models are powered by a Komatsu designed and manufactured diesel engine that features advanced engine technologies. All these are combined to achieve superior fuel economy, reduced environmental load and outstanding controllability.



**HST : Hydro-Static Transmission**  
**CLSS : Closed-center Load Sensing System**

## Superior fuel economy in high cycle operations

Komatsu's "Electronically-controlled HST", "Variable displacement pump with CLSS" and SAA4D95LE-5 diesel engine work in harmony to achieve significant fuel economy, especially in high cycle operations where fast-paced loading, unloading, and directional changes are prevalent.

## Reduced CO<sub>2</sub> emission

Komatsu's advanced engine technologies reduce environmental impact with reduced CO<sub>2</sub> emissions.

## Travel system: Komatsu's unique hydraulic drive system "Electronically-controlled HST"

The FH series employs electronically controlled hydraulic transmission, which replaces the torque converter and manual transmission found on conventional forklift trucks. The engine rotates the HST hydraulic pump, then supplies oil flow to the HST hydraulic motor and the motor drives the front wheels. Both the engine speed and the HST pump delivery are simultaneously electronically controlled to the optimum level for the situation, you can achieve optimal performance without wasting engine power and fuel.

## Lift hydraulic system: "Variable displacement pump with CLSS", a hydraulic system employed in Komatsu construction equipment

Komatsu's CLSS hydraulic system has been utilized in their hydraulic excavators for many years. In this system the load is sensed and the variable displacement pump supplies least necessary oil flow to lift the load. Compared to the conventional fixed displacement gear pump, this system provides for much greater efficiency by minimizing hydraulic oil loss, making good use of engine power and reduces overall fuel consumption.

## Variable engine output control function

The HST controller senses weight of the load, automatically sends signal to engine ECM to control engine output to balance necessary power and reduce fuel consumption.

## Auto engine shutdown function

Auto engine shutdown function is equipped as standard. If the operator applies the parking brake, sets the directional lever in the neutral position and leaves the forklift truck but without stopping the engine, the engine is automatically shutdown after a preset time. This feature contributes to prevent unnecessary fuel consumption caused by needless idling.

## Electronically-controlled HST

In this system, the engine rotates the hydraulic pump, the hydraulic power is transmitted to the hydraulic motor which is mounted directly on the drive axle, and then the tractive effort is transmitted through the differential and to the driving wheels. Since this system does not have a clutch which is a vital component for torque converter-drive forklift trucks, there is no possibility of heat loss or slippage which could be caused by the inching pedal during inching operation. Thus the system minimizes power transmission losses and reduces fuel consumption.

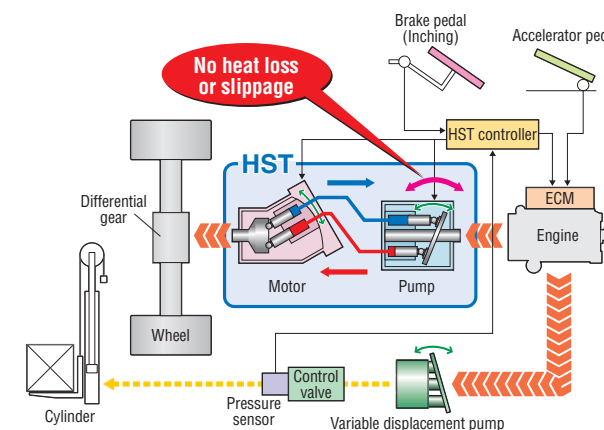

## Conventional torque converter-drive forklift truck

In this type of system, the torque converter fan that receives the engine power must rotate the other fan on the transmission side through an oil bath. Difference in the rotation speed is inevitably caused between the two fans, resulting in transmission power loss. In addition, this type of system might generate more heat and slippage due to slipping of the clutch, especially if used in a high cycle application where the inching pedal is used frequently.

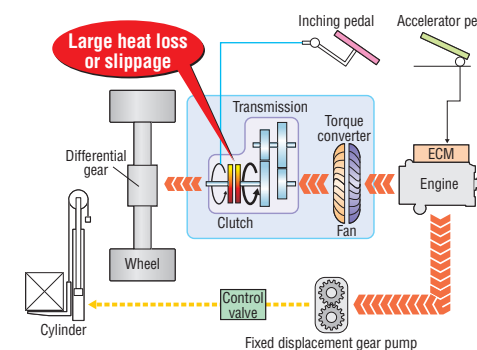

## Variable displacement pump with CLSS

Since the variable displacement pump supplies just the amount of oil needed to do specific work, there is no loss of hydraulic oil. This system makes very efficient use of the engine power, resulting in reduced fuel consumption. With this system the operator also can lift the load with the engine running at slow speeds, further reducing fuel consumption.

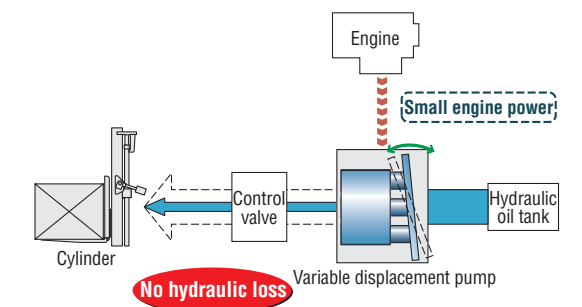

## Conventional fixed displacement gear pump

Fixed displacement gear pumps deliver a specific amount of oil per rotation, many times delivering excessive amount of oil and leading to added loading on the engine and added fuel consumption.

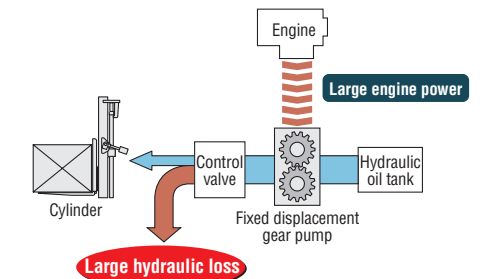

## Low emission engine

Komatsu SAA4D95LE-5, EPA Tier 4 Interim and EU Stage 3A emissions certified, turbo-charged 4-cylinder diesel engine powers the FH series forklift trucks without sacrificing power or machine productivity.

**Rated Output :**  
**50.8 kW / 2150 min<sup>-1</sup> (Net)**

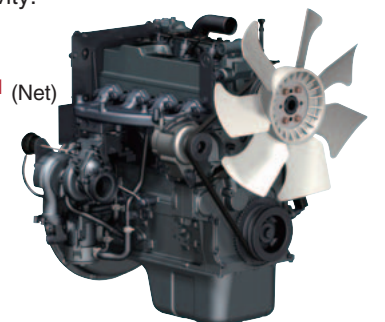



# CONTROLLABILITY AND SAFETY

## Smooth directional changes without releasing accelerator pedal

The engine is not mechanically connected to the drive system, but rather connected hydraulically to transmit tractive force, making it possible for the FH series forklift trucks to make directional changes smoothly without the need to releasing the accelerator pedal. This greatly enhances ease of operation.

\* For safety operation, slow down before directional changes.



## Controlled rolling back on a ramp

The HST drive system has a self braking feature which hydraulic flow of fluid is stopped by releasing the accelerator pedal. This feature prevents uncontrolled rolling back and holds the truck on a ramp while the operator releases the brake pedal for a ramp-start.



## Less inching pedal use means reduced operator fatigue

Travel speed can be controlled simply by the accelerator pedal, reducing the need for frequent use of the inching pedal; thereby the operator's fatigue is significantly reduced.

## No creeping

The FH series forklift trucks do not creep like conventional torque converter trucks even if the operator releases the brake pedal while the directional lever is in F or R position. This feature contributes to reduced risks in confined areas and when approaching to pick up a load.

\* For safety operation, be sure to apply the parking brake when parking the forklift truck.

## Shock-free shifting

The HST drive system is a continuously variable speed transmission and provides smooth acceleration and step-less ratio changes, thus there are less shock and worries for load shifting.

## Travel speed limiter

Travel speeds can be set in 4 stages. This function is useful to reduce speeds in tight spaces or to keep the forklift within specific in-plant speed limitations. (Set travel speed: 5, 8, 15, 23.5 km/h)



## Neutral start function

The FH series engine is only permitted to start when the operator is in the seat, the directional lever is in the neutral position and the brake pedal is kept depressed. This function prevents sudden starting of the forklift truck.



# DURABILITY AND RELIABILITY

## High-quality and reliable Komatsu components

All of the FH series main components, such as engine, hydraulic pumps, hydraulic motor, axles and controllers are designed, developed and manufactured by Komatsu, ensuring the quality and reliability that comes from exacting Komatsu engineering standards.

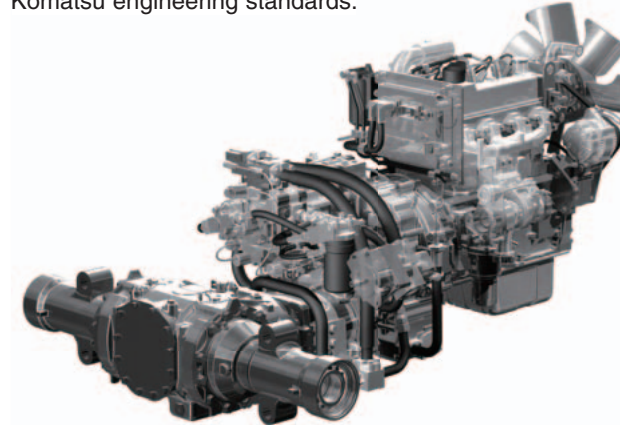

## Heavy-duty sealed wet disc brakes

The FH series forklift trucks are equipped with sealed wet disc brakes which its performance is field-proven by Komatsu construction equipment. The sealed wet disc brakes provide protection from dust, dirt and debris, providing superior durability, fade and water resistance, promoting constant and stable brake performance in high cycle operations.

Unlike the conventional drum brakes, frequent brake shoes replacements are not needed, thus downtime is reduced.

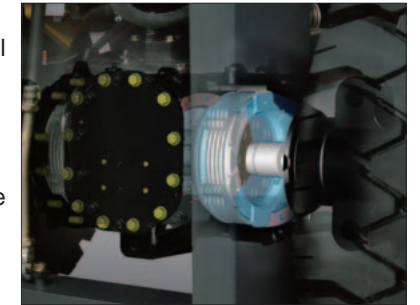

## Enhanced brake reliability

With Komatsu HST, reducing oil flow amount to the hydraulic motor helps to decelerate the forklift truck. This feature eases load on the brakes, thus, reliability of the brakes are enhanced.

## Improved engine starting performance

The FH series forklift truck uses 24 volt electrical components to improve engine starting performance. Even in cold regions, you can depend on the FH series to deliver smooth, consistent starting performance.





# KOMTRAX

## KOMTRAX as equipment to obtain machine operating information

KOMTRAX can provide various machine information including location information, operation information and fuel consumption information to the customer. In addition, to offer "Ease" and "Dependability" to the customer, Komatsu supports our customers so that they can use their Komatsu machines in best conditions at all times by using KOMTRAX information and through its services network.



**KOMTRAX**  
Assists Customer's Equipment Management and Contributes to Fuel Cost Cutting

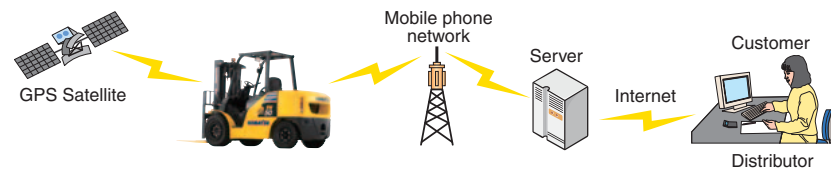

\*KOMTRAX is using the mobile phone network. It may be able to be used at the place which an electric wave does not reach, or the weak place of an electric wave.

### Machine location information

Grasping machine location information allows machine operation management.

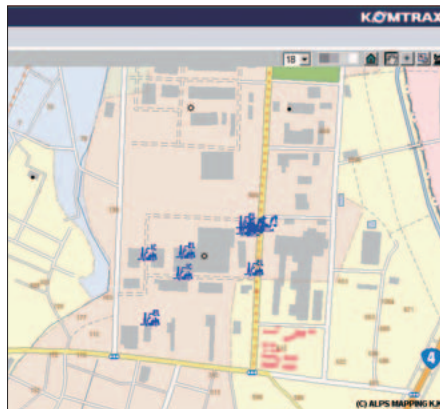

### Machine operation information

Grasping details of machine operation information on a daily basis allows grasping running costs and taking measures to reduce the costs.

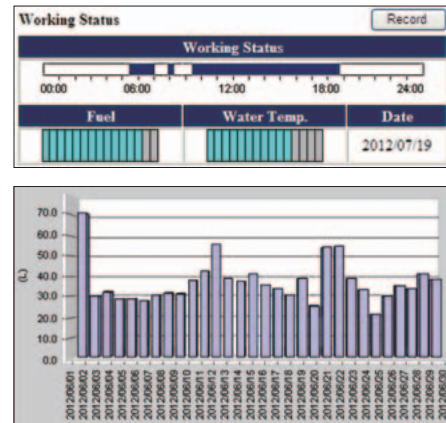

### Operation report

Monthly and annual operation records provided by KOMTRAX are useful information for the customer.

# EQUIPMENT

## STANDARD EQUIPMENT

- EPA Tier4 Interim and EU stage 3A compliant diesel engine
- Heavy duty high pressure common rail system
- Air to air charge air cooling system
- Sedimenter with priming pump
- Cyclone air cleaner (double element)
- Electronic engine control system
  - Overheat prevention function
  - Auto engine warm-up function
  - Auto air preheat function
- Auto engine shutdown function
- Variable displacement pump with CLSS (Closed-center Load Sensing System)
- Electronically-controlled HST (Hydro-Static Transmission)
- Wet disc brake
- Parking brake with release button
- Neutral start function
- Speed limiter function
- Operator presence sensing system
- Key-off lift lock
- Back-up buzzer
- Operator's seat with suspension
- Fully hydrostatic power steering
- Tilttable steering column
- Small diameter steering wheel with spinner knob
- Steering knob synchronizer function
- Standard directional lever
- Combination switch (turn signal lamp & lamp switch)
- Meter panel (safety checker)
- Engine coolant temperature gauge
- Fuel gauge
- Hour meter (service meter)
- Neutral pilot lamp
- Preheating pilot lamp
- Speed limiter pilot lamp
- Parking brake pilot lamp
- Paper binder at engine hood
- Floor mat
- Assist grip
- Halogen headlamps & rear combination lamps with bulbs
- Sealed DT connectors
- Flat face-to-face O-ring seals
- Fuel cap with key

- Tire:**
- Front single tire, pneumatic
  - Rear tire, pneumatic

- Fork:**
- 1070mm (standard for FH40,45-1)
  - 1220mm (standard for FH50-1)

## OPTIONAL EQUIPMENT

- Air cleaner with pre-cleaner, outside fitting type
- Spark-arrester
- Upward exhaust pipe (left side)
- Tilt cylinder boots
- Power steering cylinder protector plate
- Removable radiator screen & chassis under carriage protection (screen)
- Heater & defroster
- Pressure reducing valve
- Two front working lamps with LED, overhead guard mounted
- Two front working lamps with LED, fender mounted
- One rear working lamp with LED, overhead guard mounted
- Rotating lamp with LED (yellow), overhead guard mounted
- Speedometer with alarm
- Load checker with over load alarm
- Rear assist grip with horn button
- Tool kit
- Steel cab\*
- Steel cab with air conditioner\*
- Canvas cab
- Front glass with wiper
- Rear view mirror (pair)
- Headlamps & rear combination lamps with LED
- Front double tire (single size), elastic cushion
- Rear tire, elastic cushion
- Fork:
  - 1070mm (option for FH50-1)
  - 1220mm (option for FH40,45-1)
  - 1370mm
  - 1520mm
  - 1670mm
  - 1820mm
  - 1970mm
  - 2120mm
  - 2200mm

\* Order is possible from Spring of 2013.



# SPECIFICATIONS

## SPECIFICATIONS

Characteristics	Model		Manufacturer's Designation		FH40-1	FH45-1	FH50-1
	1.2	Model		Manufacturer's Designation		FH40-1	FH45-1
1.3	Power Type		Electric, Diesel, Gasoline, LPG, Cable		Diesel	Diesel	Diesel
1.4	Operation Type		Sitting		Sitting	Sitting	Sitting
1.5	Rated Capacity	Q	Rated Capacity	kg	4000	4500	5000
1.6	Load Center	c	Rated Load Center	mm	600	600	600
1.8	Load Distance	x	Front Axle Center to Fork Face	mm	580	590	575
1.9	Wheelbase	y		mm	2000	2000	2000
2.1	Service Weight			kg	6290	6920	7380
2.2	Axle Loading	Loaded	Front	kg	9000	9960	10925
2.2.1			Rear	kg	1290	1490	1455
2.3			Unloaded	Front	kg	2590	2750
2.3.1		Rear		kg	3700	4170	4480
3.1		Tire Type				Pneumatic	Pneumatic
3.2		Tire Size	Front		300-15-18PR(I)	300-15-18PR(I)	300-15-18PR(I)
3.3		Rear		7.00-12-12PR(I)	7.00-12-14PR(I)	7.00-12-14PR(I)	
3.5	Number of Wheel	Front/Rear (x=driven)		2x/2	2x/2	2x/2	
3.6	Tread, Front	b10		mm	1225	1225	1225
3.7	Tread, Rear	b11		mm	1120	1120	1120
4.1	Tilting Angle	a / b	Forward/Backward	degree	6/12	6/12	6/12
4.2	Mast Height, Lowered	h1	2-stage Mast	mm	2105	2205	2205
4.3	Std. Free Lift	h2	2-stage Std. Mast, from Ground	mm	150	145	140
4.4	Std. Lift Height	h3	2-stage Std. Mast, from Ground	mm	3000	3000	3000
4.5	Mast Height, Extended	h4	2-stage Std. Mast	mm	4130	4130	4345
4.7	Height, Overhead Guard	h6		mm	2240	2240	2240
4.19	Length, with Std. Forks	L1		mm	4220	4270	4405
4.20	Length, to Fork Face	L2		mm	3150	3200	3185
4.21	Width, at Tire	b1	Single	mm	1520	1520	1520
4.22	Forks	s/e/l	Thickness x Width x Length	mm	55 x 150 x 1070	55 x 150 x 1070	55 x 150 x 1220
4.23	Fork Carriage Class	ISO 2328, Type A/B/no			class3, A	class3, A	class4, A
4.24	Width, Fork Carriage	b3		mm	1190	1190	1270
4.31	Ground Clearance	m1	Under Mast	mm	145	145	145
4.32		m2	at Center of Wheelbase	mm	210	210	210
4.33	Aisle Width *	Ast	with L1000 x W1200 pallet	mm	4695	4755	4920
4.34		Ast	with L1200 x W800 pallet	mm	4825	4885	4920
4.35	Turning Radius	Wa		mm	2845	2895	2925
5.1	Travel Speed (FWD)	Loaded		km/h	23.5	23.5	23.5
5.2		Unloaded		km/h	23.5	23.5	23.5
5.2	Lifting Speed	Loaded		mm/s	485	420	420
5.3		Unloaded		mm/s	505	440	440
5.3	Lowering Speed	Loaded		mm/s	500	500	500
5.6		Unloaded		mm/s	500	500	500
5.6	Max. Drawbar Pull	Loaded 1.5 km/h, 3 min rating		kN	34	34	35
5.8	Max. Gradeability	Loaded 1.5 km/h, 3 min rating		%	33	29	28
5.10	Service Brake	Operation/Type			Foot/Hydraulic	Foot/Hydraulic	Foot/Hydraulic
5.11	Parking Brake	Operation/Control			Hand/Mechanical	Hand/Mechanical	Hand/Mechanical
5.12	Steering	Type			FHPS	FHPS	FHPS
6.4	Battery	Voltage/Capacity at 5-hour rating		V/Ah	24/52	24/52	24/52
7.1	Make				KOMATSU	KOMATSU	KOMATSU
7.2	Model				SAA4D95LE-5	SAA4D95LE-5	SAA4D95LE-5
7.3	Rated Output, SAE net			kW	50.8	50.8	50.8
7.3.1	Rated RPM			min <sup>-1</sup>	2150	2150	2150
7.4	Max. Torque, SAE net			Nm/min <sup>-1</sup>	287/1400	287/1400	287/1400
7.6	No. of Cylinder/Displacement			cm <sup>3</sup>	4/3260	4/3260	4/3260
8.2	Fuel Tank Capacity			L	105	105	105
8.2.1	Relief Pressure for Attachment			Mpa	20.6	20.6	20.6
8.2.1	Hydraulic tank Capacity			L	83	83	83
8.7	Transmission				Hydrostatic	Hydrostatic	Hydrostatic

\* : VDI 2198 includes 200 mm clearance

## LOAD CAPACITY CURVE

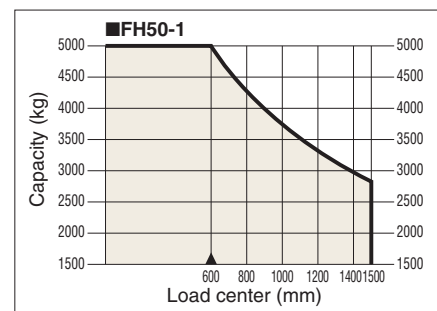
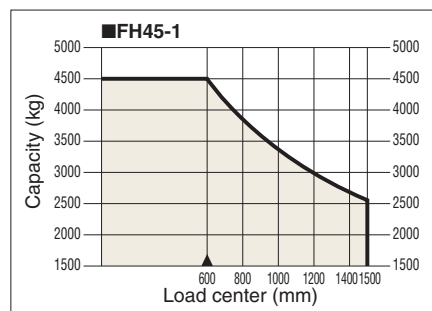
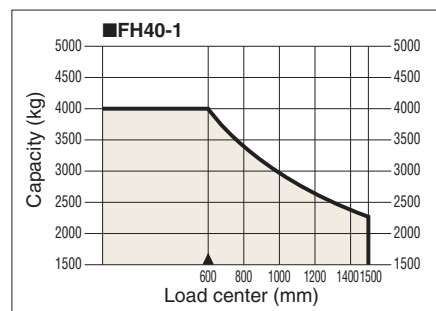

## DIMENSIONS

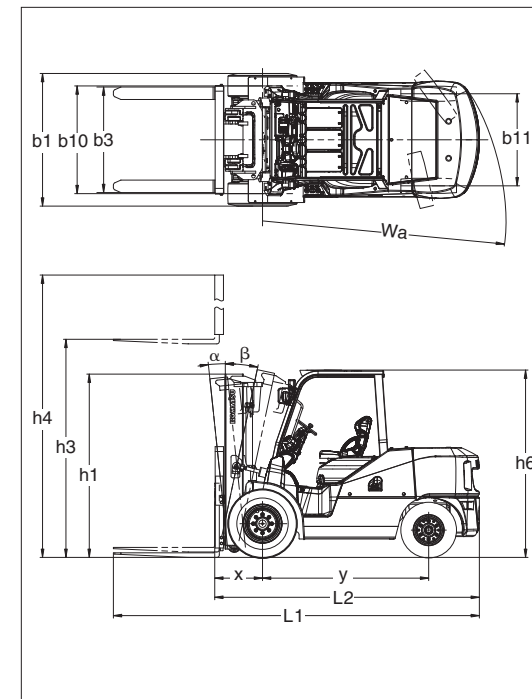

## AISLE WIDTH

model	Length of pallet (mm)	Width of pallet (mm)						
		800	900	1000	1100	1200	1300	1400
FH40-1	800	4695	4695	4695	4695	4695	4695	4695
	900	4695	4695	4695	4695	4695	4695	4695
	1000	4695	4695	4695	4695	4695	4695	4695
	1100	4725	4725	4725	4725	4725	4725	4725
	1200	4825	4825	4825	4825	4825	4825	4825
	1300	4925	4925	4925	4925	4925	4925	4925
FH45-1	800	4755	4755	4755	4755	4755	4755	4755
	900	4755	4755	4755	4755	4755	4755	4755
	1000	4755	4755	4755	4755	4755	4755	4755
	1100	4785	4785	4785	4785	4785	4785	4785
	1200	4885	4885	4885	4885	4885	4885	4885
	1300	4985	4985	4985	4985	4985	4985	4985
FH50-1	800	4920	4920	4920	4920	4920	4920	4920
	900	4920	4920	4920	4920	4920	4920	4920
	1000	4920	4920	4920	4920	4920	4920	4920
	1100	4920	4920	4920	4920	4920	4920	4920
	1200	4920	4920	4920	4920	4920	4920	4920
	1300	5000	5000	5000	5000	5000	5000	5000
1400	5100	5100	5100	5100	5100	5100	5100	

## MAXIMUM LOAD AND OVERALL HEIGHT OF MAST BY LIFTING HEIGHT

### 2-stage free view mast (single tire, load center 600 mm)

maximum fork height (mm)	model	Load capacity (kg)			Overall height [Lowered / Extended] (mm)		
		FH40-1	FH45-1	FH50-1	FH40-1	FH45-1	FH50-1
3000		4000	4500	5000	2105/4130	2205/4130	2205/4345
3300		4000	4500	5000	2255/4430	2355/4430	2355/4645
3500		4000	4500	5000	2355/4630	2455/4630	2455/4845
4000		4000	4500	5000	2655/5130	2755/5130	2755/5345
4500		4000	4500	5000	2905/5630	3005/5630	3005/5845
5000		4000	4000	4000	3205/6130	3305/6130	3305/6345
6000		2400	2200	2200	3705/7130	3805/7130	3805/7345

### 3-stage full free view mast (single tire, load center 600 mm, 3-cylinder type)

maximum fork height (mm)	model	Load capacity (kg)			Overall height [Lowered / Extended] (mm)		
		FH40-1	FH45-1	FH50-1	FH40-1	FH45-1	FH50-1
3700		4000	4500	4800	1905/4870	2005/4920	2155/5135
4000		4000	4500	4600	2005/5170	2105/5220	2255/5435
4300		4000	4400	4600	2105/5470	2205/5520	2355/5735
4500		4000	4250	4500	2205/5670	2305/5720	2455/5935
4700		3800	4200	4500	2305/5870	2355/5920	2505/6135
5000		3500	4100	4100	2405/6170	2455/6220	2605/6435
6000		2200	2300	2350	2755/7170	2805/7220	2955/7435

### 2-stage full free view mast (single tire, load center 600 mm, 3-cylinder type)

maximum fork height (mm)	model	Load capacity (kg)			Overall height [Lowered / Extended] (mm)		
		FH40-1	FH45-1	FH50-1	FH40-1	FH45-1	FH50-1
3000		4000	4500	4800	2105/4130	2205/4140	2205/4355